



Smarter Storage Solutions.

High-Density Storage – up to 300% more space than traditional solutions

In 1975 Business Week magazine predicted the imminent arrival of the paperless office. Look around and you're probably wondering what happened to that idea?*

Our high-density systems let you store more files and boxes (or pretty much anything else for that matter) in the same floor space as traditional filing cabinets.

So you can use more of your valuable office space more profitably.

It's a real bonus - no bad thing when you consider Central London rents currently average £100+/square metre.



So you can fit more staff into the same space and make your office more productive. And expand as your business grows without taking on more expensive floor space.

It's simple. Our systems remove the need for aisles and use the full height of your office. So you get 100% more storage than static shelving and 300% more than traditional 4-drawer filing cabinets.

Take a look at our range – there's sure to be a solution for you.

*It's probably 'filed' under a pile of paper somewhere.

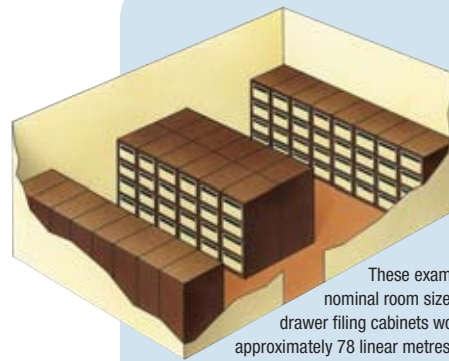

These examples are based on a nominal room size 5.5 x 4 metres. 28 four drawer filing cabinets would provide approximately 78 linear metres of filing.

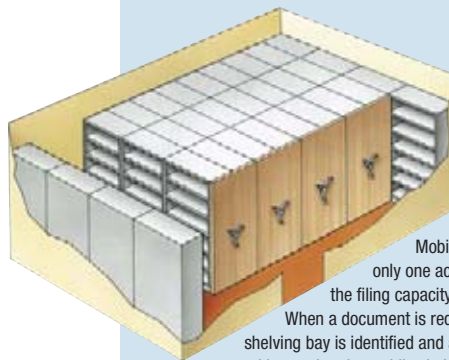

Mobile shelving which uses only one access aisle increases the filing capacity to 192 linear metres. When a document is required the particular shelving bay is identified and an adjacent aisle created by moving the mobile shelving units apart.

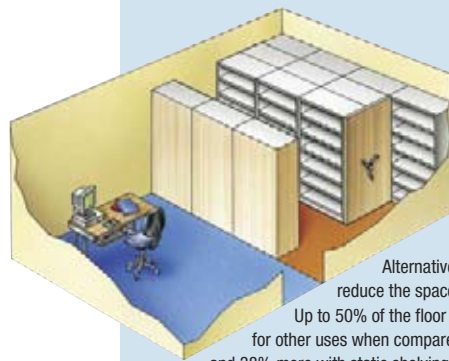

Alternatively Mobile shelving can reduce the space required for storage. Up to 50% of the floor space can be released for other uses when compared with filing cabinets and 38% more with static shelving.



Cert No FM 09409



Cert No EMS 515593

Mobles and shelving are manufactured in **BS EN ISO 9000** and **ISO 14001** accredited factories.

BS EN ISO 9000 shows that our Quality Management Systems comply to the latest international standards.

ISO 14001 reflects our commitment to reduce carbon footprint and minimise any adverse environmental impact throughout the design and manufacturing process.



LD250

LIGHT DUTY

High-Density Solutions for Small Offices.

LD250 Light Duty Mobile Shelving System is perfect for small offices. It's easy to specify and offers an instant solution to your storage issues:

- Fast to install - no disruption to your business
- Tracks laid and fixed directly to the existing flooring
- Simple to maintain and operate

It's great for all sorts of uses, including retail stock applications. For example, you could store small items like shoes, storing more stock in less space and freeing up more valuable retail floor space.

Maximum Bay Load	250kg*
Maximum Base Load	750kg*
Maximum Base Length	3.6m
Maximum Base Depth	1.2m

*Uniformly Distributed Load



Simple push/pull operation.



Footbrakes on each unit prevent mobiles moving when someone is in one of the aisles.

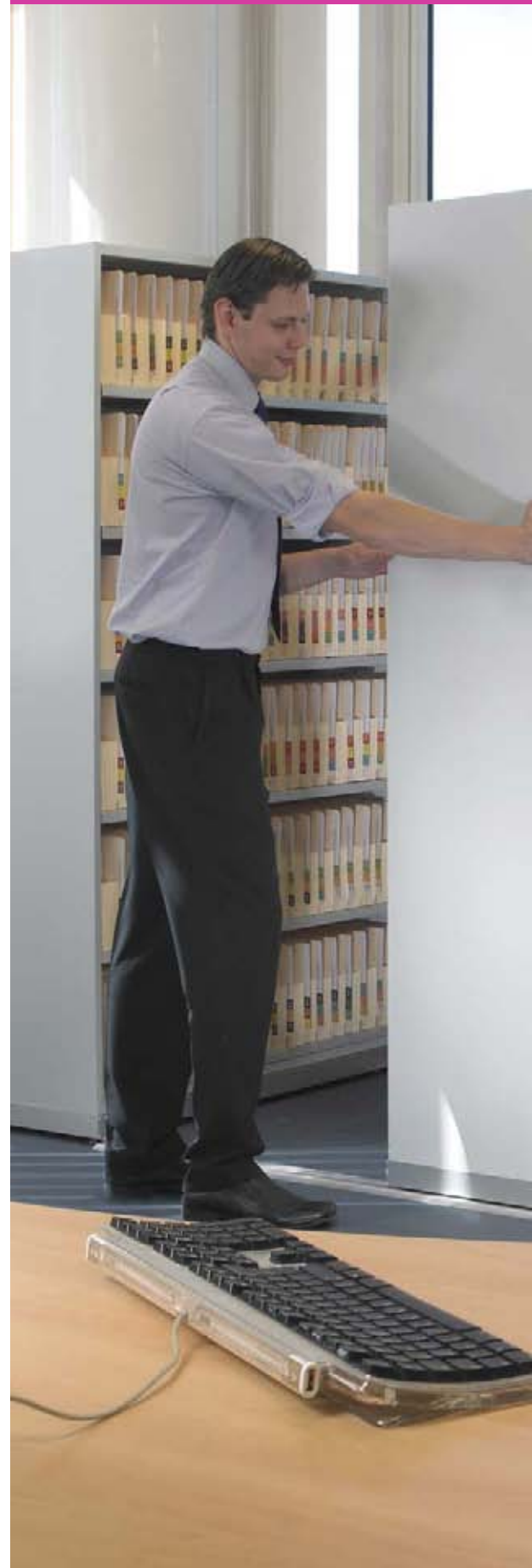



Quick to fit, simple to use.
The perfect solution for
small offices.



Expansive Storage in a Tight Space.

If you've got odd corners, corridors and alcoves, **LD250** in a Move-a-side configuration can help you make the most of every inch. It can increase storage capacity by 75-90% compared to ordinary shelving.

- Simple manual push/pull operation
- Doubles the number of units against a wall
- Fully flexible - extend, shrink or relocate with a minimal disruption

If you need secure units, tambour door cabinets can be used as an alternative - see page 18 for more details.



Take Control of your Workspace.



Make the most of your workspace with our **MD500** Medium Duty Mobile Shelving System. Perfect for everyday storage of files, small archives or even for stock in larger retail units. It's as versatile as your needs and can be combined with all our shelving systems including Stormor and Euroshelving.

- A choice of decorative end panels can be added - see p.10
- Choose push/pull, hand wheel-driven or FollowMe electric drive systems – see p12
- Combine with track systems to fit any floor - see p.15
- Locking options available for added security – p.14
- Modular construction – move or extend as your business develops

Maximum Bay Load	500kg*
Maximum Base Load	5000kg*
Maximum Base Length	7.2m
Maximum Base Depth	1.2m

*Uniformly Distributed Load

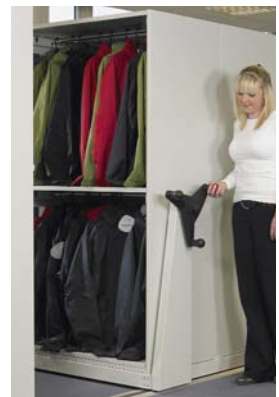
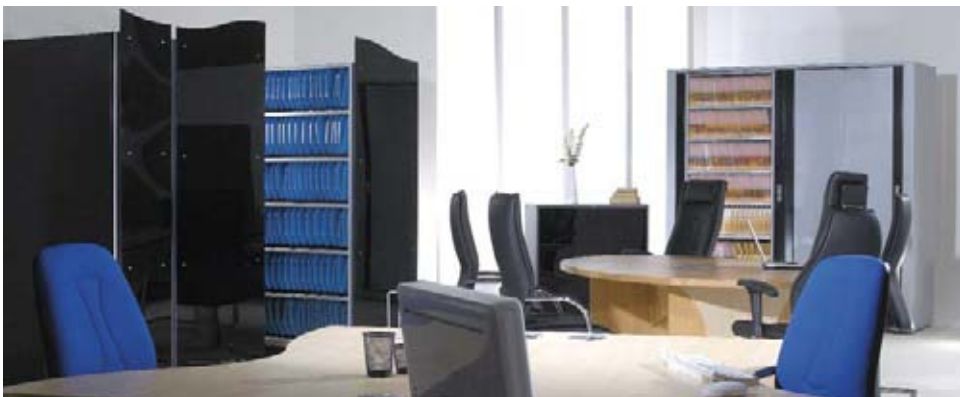



Modular system –
moves and extends with
your business.



HD1000

HEAVY DUTY



Take on the biggest storage problems and win.





Big Solutions for the Biggest Storage Needs.

If you've got lots of stuff to store, be it bulk storage, large archives or stock the **HD1000** Heavy Duty Mobile Shelving System can handle all that and more. This versatile system makes the maximum use of the biggest spaces, allowing you to store more than you ever thought possible.



- Fits any environment with a choice of decorative end panels that can be added - see p.10
- Choose push/pull, hand wheel-driven or FollowMe electric drive systems - see p12
- Works with all our shelving systems including Stormor, Euro and Longspan
- Combine with track systems to fit any floor - see p.15
- Security locking options available for added security – p.14

Maximum Bay Load	1000kg*
Maximum Base Load	20,000kg*
Maximum Base Length	15m
Maximum Base Depth	1.5m

*Uniformly Distributed Load



Look the business.

End panels of the mobile carriages can be tailored to suit the aesthetics of your installation.

Limited only by imagination, these optional end panels can be created to complement the decor of the surrounding environment. These can be acrylic, steel, melamine, fabric or graphic panels to match the desired interior finish.



MFC (melamine faced chipboard) panels in a variety of wood grain finishes can be fitted to enhance the mobiles appearance..

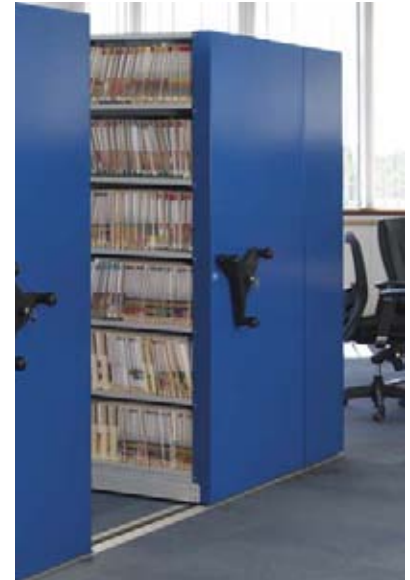

Steel panels, sprayed to customer requirements to match surrounding decor.



Matt or gloss acrylic panels are available in a wide range of colours.

Back Panels

If the mobile is not positioned into a corner, but adjacent to a walkway, back panels are available for the static bays which create a clean, smooth finish.



Panels are available with fabric finish.

GRAPHIC PANELS



Make a statement.

Add a striking, dynamic edge to your working environment.

Not only do our storage systems change the way you use space, you can also make a statement about your business using graphic panels. These can cover the whole width of a mobile unit to create an impressive focal point. You can feature anything from your own or commissioned photographs to corporate graphics, making even the most utilitarian office space feel vibrant and dynamic.

Instant Access - No Sweat.

We have a number of Drive Systems to choose from, each designed to work with our different storage solutions. They're simple to use, quick and take the hard work out of getting to the document or stock you need.



FollowMe Electronic Control

Now you can move large sections of mobile shelving at the touch of a button with the safest mobile system on the market.

Our new FollowMe electronic controls are simple to use. They run off a safe 12v power supply that connects to the mains using a standard power socket. Compared to other electronic systems they're a lot less complicated and have no need for expensive safety sensors.

The system is designed to ensure complete safety of both the operator and anyone else working within an aisle. Units are operated from the closing aisle so that you can see if there is anyone inside or if there are any obstructions

- FollowMe frees up more useable space for additional shelving. Because it uses neat, discreet buttons, with no protruding handles it can make a significant difference.
- Unit status - light-up buttons quickly tell you whether the unit is charging, waiting to move or needs recharging.
- Locking option available.



CE marking is a declaration that our FollowMe Mobile system meets all the appropriate provisions of the relevant legislation implementing certain European Directives. The initials "CE" ultimately mean that FollowMe satisfies the applicable European Directive(s).

FollowMe Operating Sequence see the FollowMe drive in action at www.followmemobile.co.uk



Press the button on the bay adjacent to the aisle you wish to access, in the direction you require the base to move. The button will flash when activated.



Press in the corresponding buttons on the intermediate mobiles until you get to the aisle that is to be closed.



Close the aisle by keeping the button depressed on the mobile.

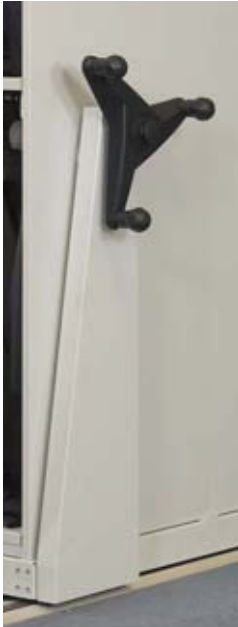

Manually Assisted

This stylish hand-wheel design is unique. Geared operation makes light work of shifting heavily loaded mobiles. Fitted with an aisle safety lock as standard, users can operate in the aisles with complete peace of mind.



Push/Pull

It doesn't get simpler than this. Shelving glides along on its tracks, set in motion using this simple solution. Manual handling regulations mean this is only fitted to smaller mobile systems.



With base moving the operator is correctly positioned to ensure the closing aisle is clear of obstructions.



While the first base is moving all other activated bases will follow.



Bases will automatically park up to allow access to the newly opened aisle.

LOCKING

OPTIONS

Keep it safe.

There are many reasons to fit security measures to our mobile shelving systems.

We offer a number of solutions to keep confidential documents, data protected material and high value items. These work by immobilising the whole system once it is closed.



Aisle safety lock

Push/pull locking, supplied as standard on all hand-wheel driven systems.



Optional security lock

Available as an optional extra on our hand-wheel driven systems. A simple-to-operate security measure.



Shoot bolt lock

For added security this key operated lock can be fitted to all our mobile shelving systems. It can be hidden behind decorative end panels and works by engaging the solid steel bar with a dedicated floor slot.

It comes with a closed/open indicator and the keys can be matched to other locks (for example, the door to the room where the storage system is situated) so you need fewer keys.



Electric lock

An optional electric lock can be fitted to FollowMe electric drive units. This breaks the electrical circuit and stop the drive system from operating.

Smooth and precise operation.

Choose the right track option to suit the environment. Our range of tracks ensures smooth and accurate operation for new or existing floors.

Uneven Floors

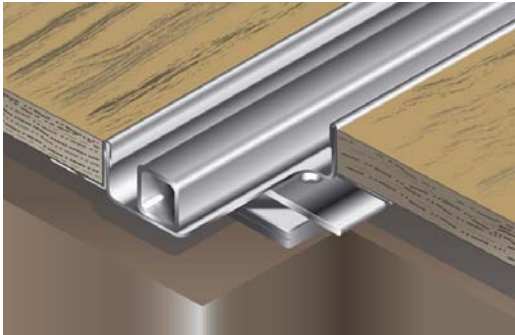

Infill Floor Track

Suitable for floors with an average flatness of 15mm over the floor. Floors are shimmed but not fixed preventing any need to put holes into the existing floor allowing easy relocation at a later date. An infill floor is fitted, ensuring a smooth trip free floor surface between tracks. Alternative finishes can be supplied. Ramps and trim are fitted to all edges of the floor.



Infill Floor Track - Fixed

Floors are shimmed and fixed to cater for higher loads than non-fixed systems, but still allowing relocation at a later date. Suitable for floors with an average flatness of 15mm over the floor. Floors with levels outside this will need additional shims or consideration should be made to improve the floor prior to fitting the track. For example screed or a false structural floor. An infill floor is fitted, ensuring a smooth trip free floor surface between tracks. Alternative finishes can be supplied. Ramps and trim are fitted to all edges of the floor.

Flat Floors

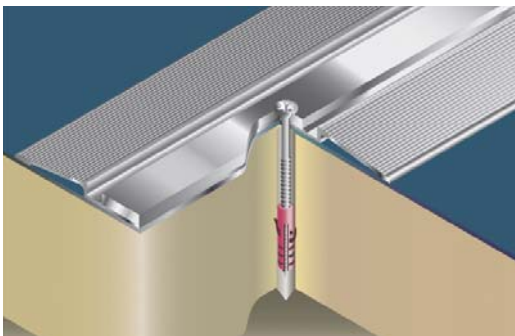

Surface Profile Track

A simple, quick to install and cost effective system for flat floors. Aluminium extruded ramp with steel inset is fixed directly onto the floor and is suitable for floors with a flatness of 1mm in every 1000mm in all directions. A typical application would be a raised floor in an office.

New Floors



In-situ track

No ramps are required for this system making it ideal for wheeled traffic. Suitable for new buildings where the final finished floor surface has not been laid. The track is levelled and fixed using nuts above and below the foot plate. For existing floors channels 200mm wide x 50mm deep can be used (subject to floor suitability).



Compact and secure, Atlantic Rotary Cabinets give you speedy access to documents or stock when you need it.

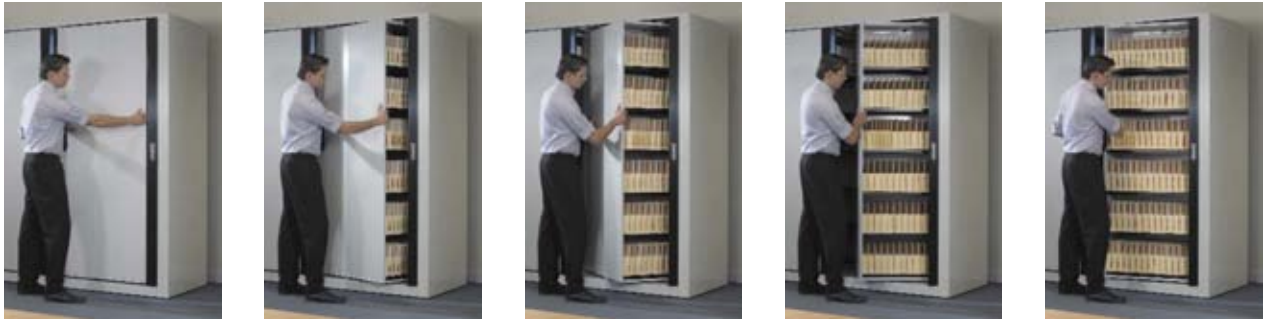

Everything to hand when you need it.

Today's office environment creates demands for efficiency in filing and document management.

Atlantic Rotary Cabinets offer high-density, secure storage for all those files you need to consult frequently. No more rooting through filing cabinets or having to leave the office to find a vital document, these cabinets keep everything you need close to where its needed.

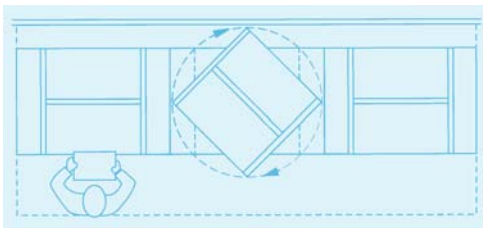

Atlantic offers:

- 40% saving in space
- Up to 50% reduction in access times
- High levels of security

These neat units feature double-sided Stormor shelving bays that rotate on a central axis - giving you access to over 10.5 linear metres of filing in one place. Finding what you need (and refilling it) is quick and simple.

You can keep important files safe and secure with the built-in locking system when it's not in use. Or you can lock it in the open position to restrict access to one picking face, keeping the rest of the contents secure.

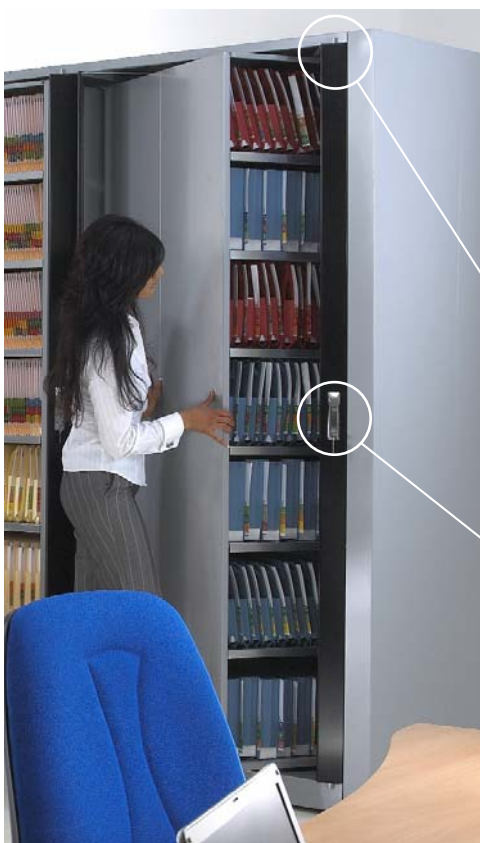

Unique 'flipper' opening action

Conventional rotary units are often fitted with rubber strips that allow people to get a hand into a locked rotary and gain access to the files or valuables. Atlantic rotary cabinets overcome this security risk thanks to a unique locking and opening system. It increases the space available at the sides of the picking faces to allow easy rotation of the unit. Simply unlock, turn the handle and the 'flipper' swings clear of the unit.

Secure storage for today's working office.

We offer a range of steel storage cabinets in a variety of styles, sizes and colours to meet the needs of today's office environment

Side opening **TAMBOUR** cabinets have been designed to maximise storage capacity and make the most of valuable office space, with the tambour blind stretching into the cabinet's sides and utilising less space. Unlike conventional cupboards, **TAMBOUR** cabinets have no doors that open outwards to cause obstructions. They are available in 6 standard heights with a choice of colours and finishes.





Combining secure file storage with high density. Standard tambour door cabinets can be mounted on tracks in both move-a-way and move-a-side configurations.



TWO TIER SHELVING



INDUSTRIAL SHELVING



JUST SHELVING



PALLET RACKING



SQUARE TUBE



SMALL PARTS STORAGE



HEAVY DUTY SHELVING



PERSONAL STORAGE



AVANTA

Tel: **0800 975 4933**

Sales: sales@avantauk.com

Unit B1 - Astra Park - Parkside Lane - Leeds - LS11 5SZ